



US010056184B2

(12) **United States Patent**
Daily et al.

(10) **Patent No.:** **US 10,056,184 B2**
(45) **Date of Patent:** **Aug. 21, 2018**

(54) **SEGMENTED CORE CAP SYSTEM FOR TOROIDAL TRANSFORMERS**

4,779,812 A * 10/1988 Fisher H01F 27/322
242/434.7

(71) Applicants: **Madison Daily**, Rolla, MO (US); **John Park**, Rolla, MO (US)

4,847,583 A 7/1989 Bernard
5,543,773 A 8/1996 Evans et al.
5,828,282 A 10/1998 Tiemann
5,952,907 A 9/1999 McWilliams et al.

(72) Inventors: **Madison Daily**, Rolla, MO (US); **John Park**, Rolla, MO (US)

6,300,857 B1 10/2001 Herwig
6,507,260 B1 1/2003 Baumann et al.
7,312,686 B2* 12/2007 Bruno H01F 27/263
336/229

(*) Notice: Subject to any disclaimer, the term of this patent is extended or adjusted under 35 U.S.C. 154(b) by 35 days.

2004/0130428 A1 7/2004 Mignano
2010/0323900 A1* 12/2010 Kawashima H01F 6/065
505/211

(Continued)

(21) Appl. No.: **14/887,824**

FOREIGN PATENT DOCUMENTS

(22) Filed: **Oct. 20, 2015**

GB 1079935 8/1967
JP 2000299226 10/2000

(65) **Prior Publication Data**

(Continued)

US 2017/0110238 A1 Apr. 20, 2017

(51) **Int. Cl.**

Primary Examiner — Mangtin Lian

H01F 27/30 (2006.01)
H01F 27/32 (2006.01)
H01F 41/08 (2006.01)
H01F 41/098 (2016.01)

(74) *Attorney, Agent, or Firm* — C John Brannon;
Brannon Sowers & Cracraft PC

(52) **U.S. Cl.**

(57) **ABSTRACT**

CPC **H01F 27/325** (2013.01); **H01F 41/08**
(2013.01); **H01F 41/098** (2016.01)

A modular toroidal transformer core cap system, including a plurality of cap segments, wherein each respective cap segment further includes first and second spaced elongated wall members, first and second connector members connected to the respective first and second elongated wall members, and a generally flat panel member connected to and extending between the first and second elongated wall members. The first and second wall members are disposed at a predetermined angle relative one another and the first and second elongated wall members and the panel member are electrically nonconducting. An integral number of cap segments may be joined together to define an annular core cap.

(58) **Field of Classification Search**

CPC H01F 27/325; H01F 41/08; H01F 41/098;
H01F 5/02; H01F 27/324; H01F 17/06;
H01F 17/062; H01F 30/16
USPC 336/198, 208, 229, 199, 196, 211, 219;
29/605

See application file for complete search history.

(56) **References Cited**

U.S. PATENT DOCUMENTS

3,340,489 A * 9/1967 Bastis B01J 21/02
336/192
4,728,919 A 3/1988 Dirmeyer

13 Claims, 15 Drawing Sheets

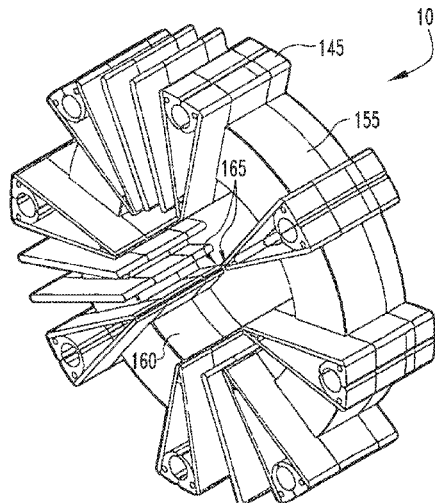

(56)

References Cited

U.S. PATENT DOCUMENTS

2011/0025304 A1* 2/2011 Lint G01R 15/181
324/150
2011/0133874 A1* 6/2011 Prabhakaran H01F 17/02
336/200

FOREIGN PATENT DOCUMENTS

KR 101101676 10/2001
WO 2005004181 1/2005

* cited by examiner

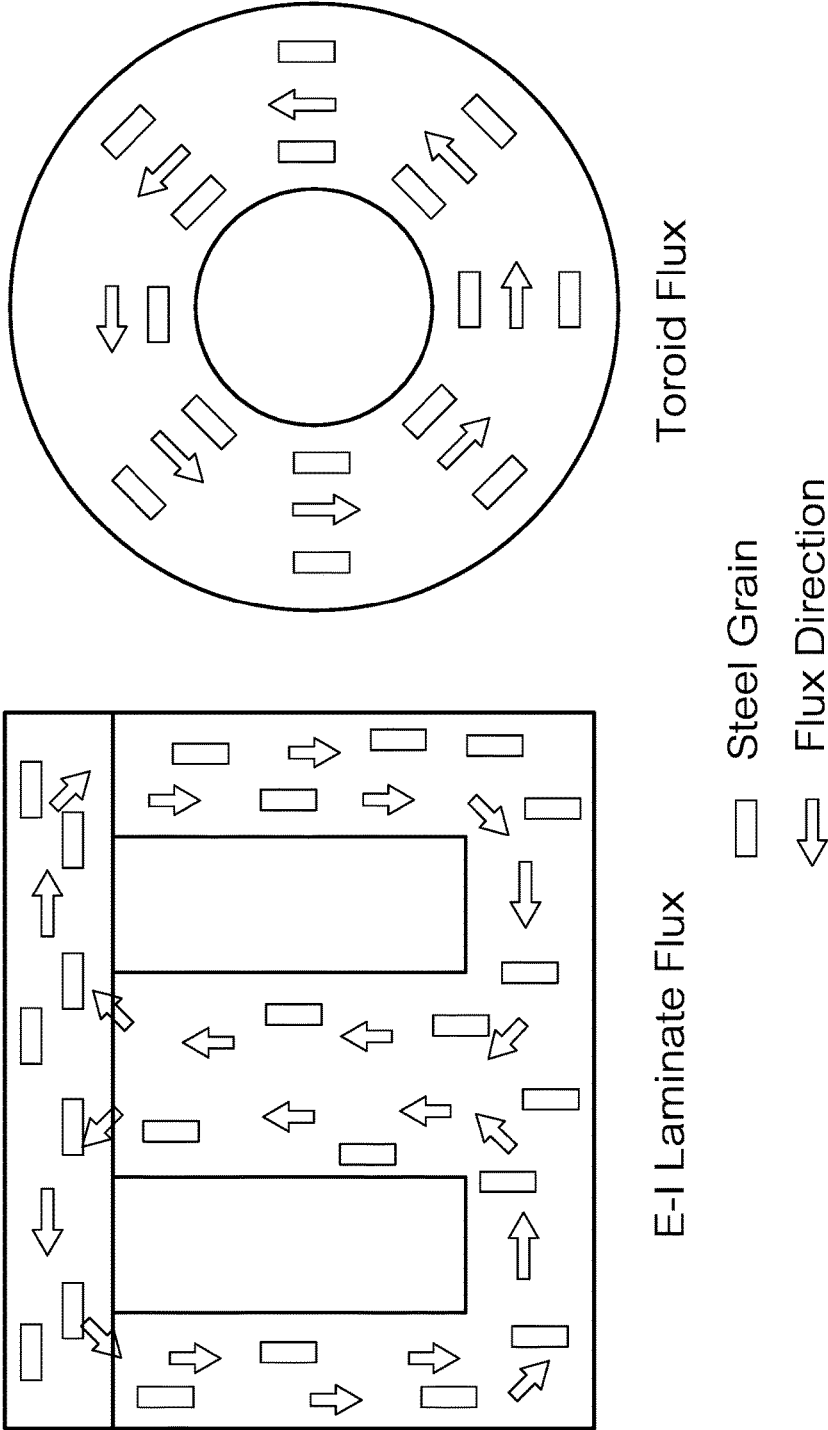

Fig. 1
(Prior Art)

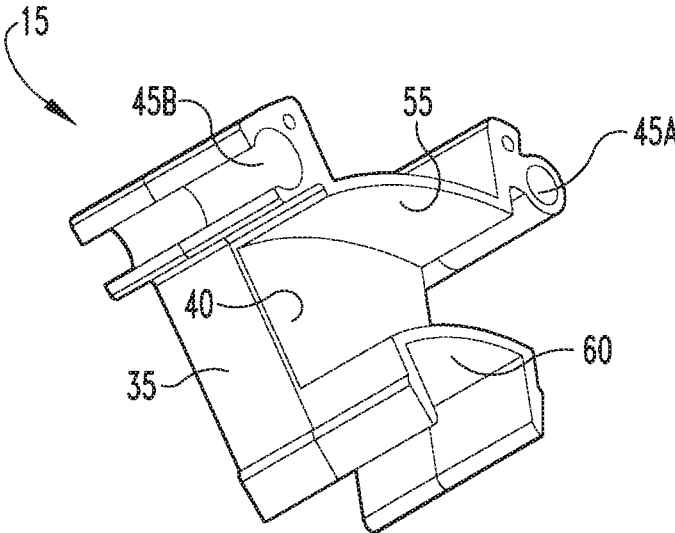

Fig. 2A

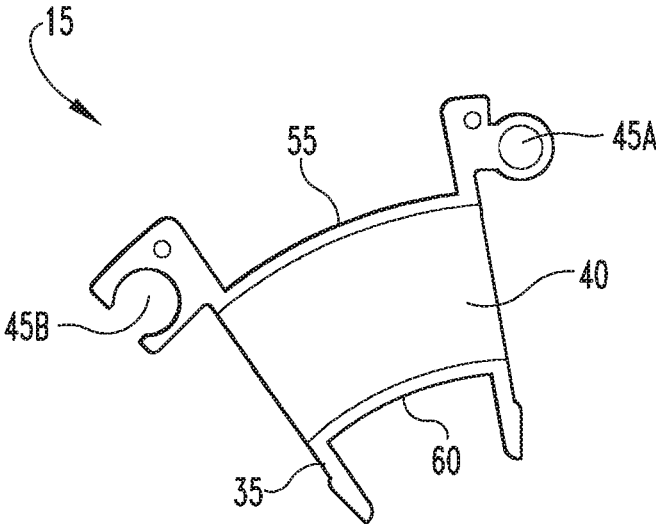

Fig. 2B

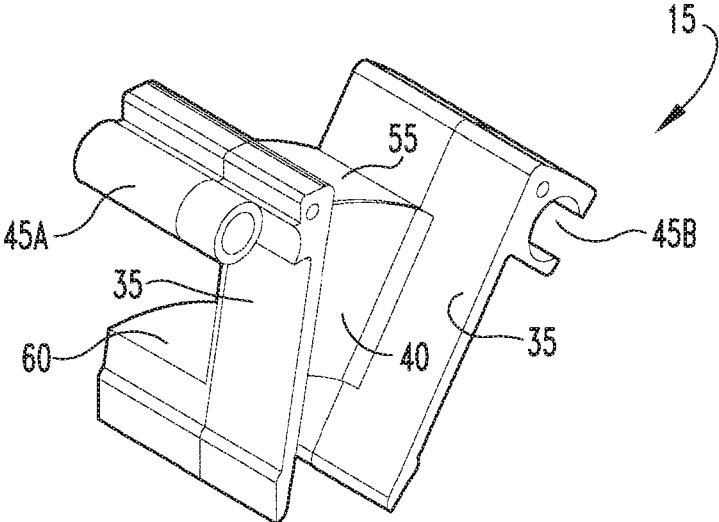

Fig. 2C

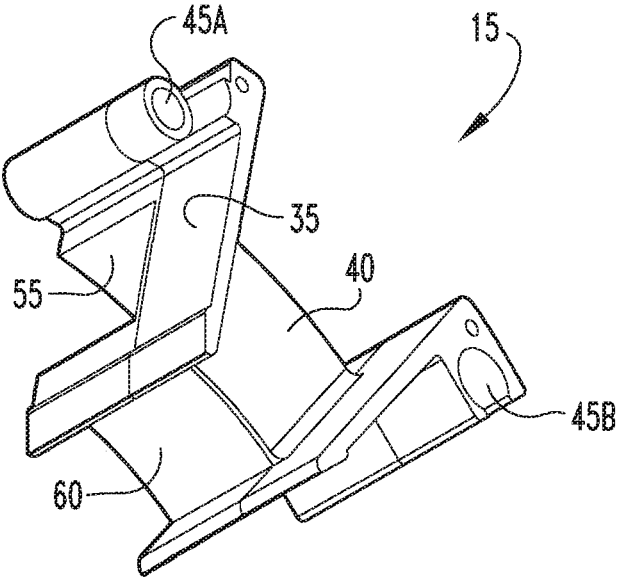

Fig. 2D

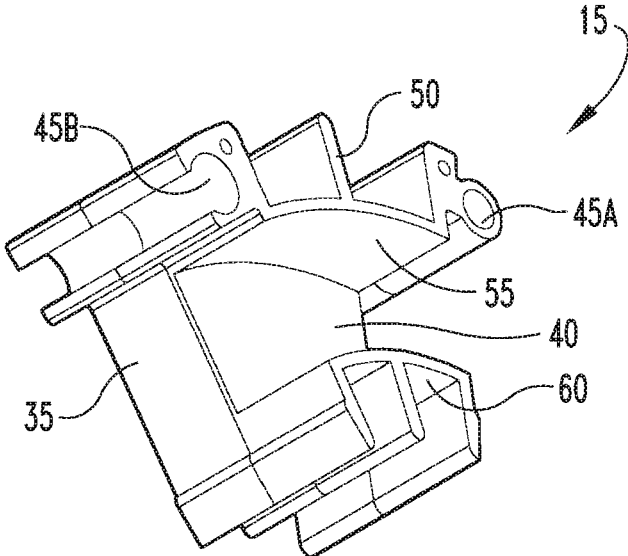

Fig. 3 A

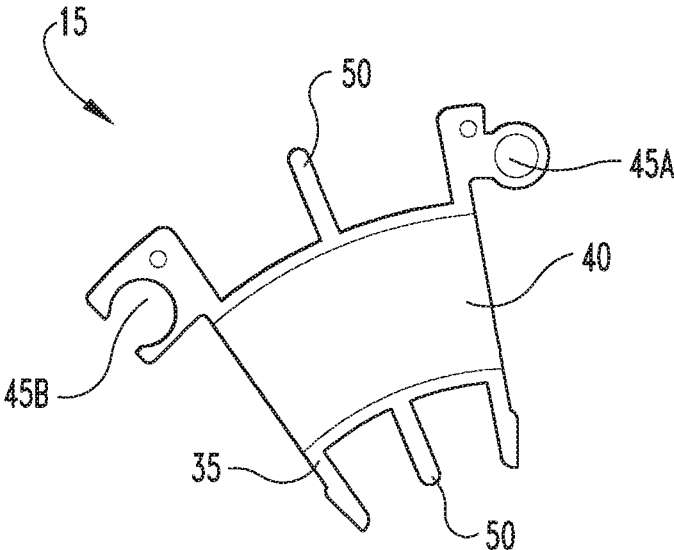

Fig. 3 B

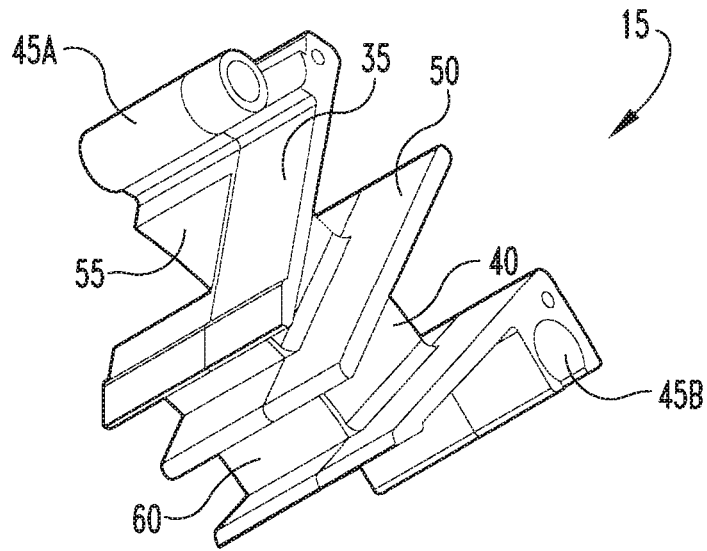

Fig. 3 C

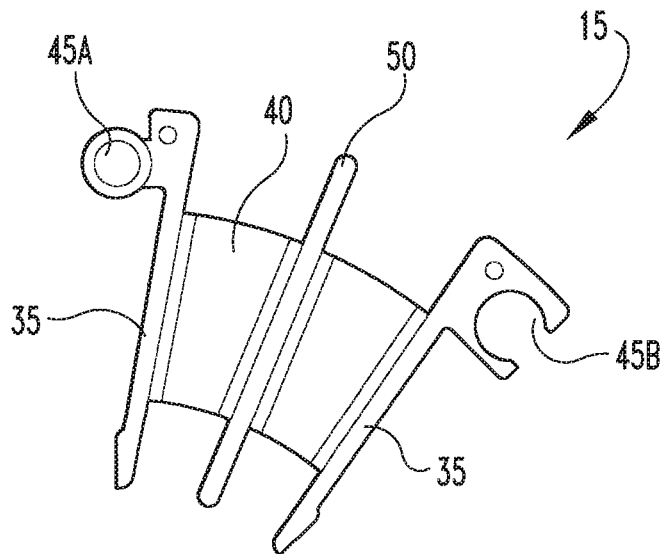

Fig. 3 D

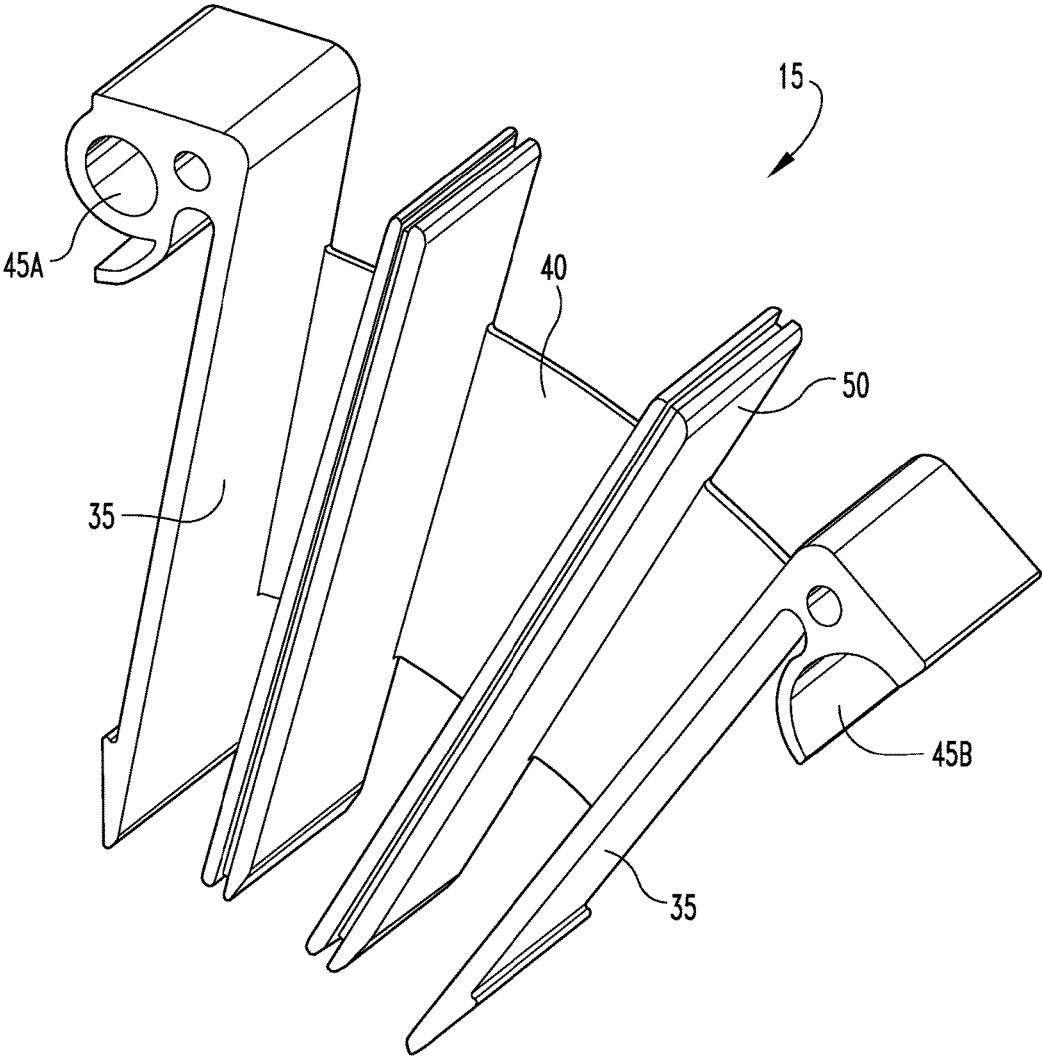

Fig. 4

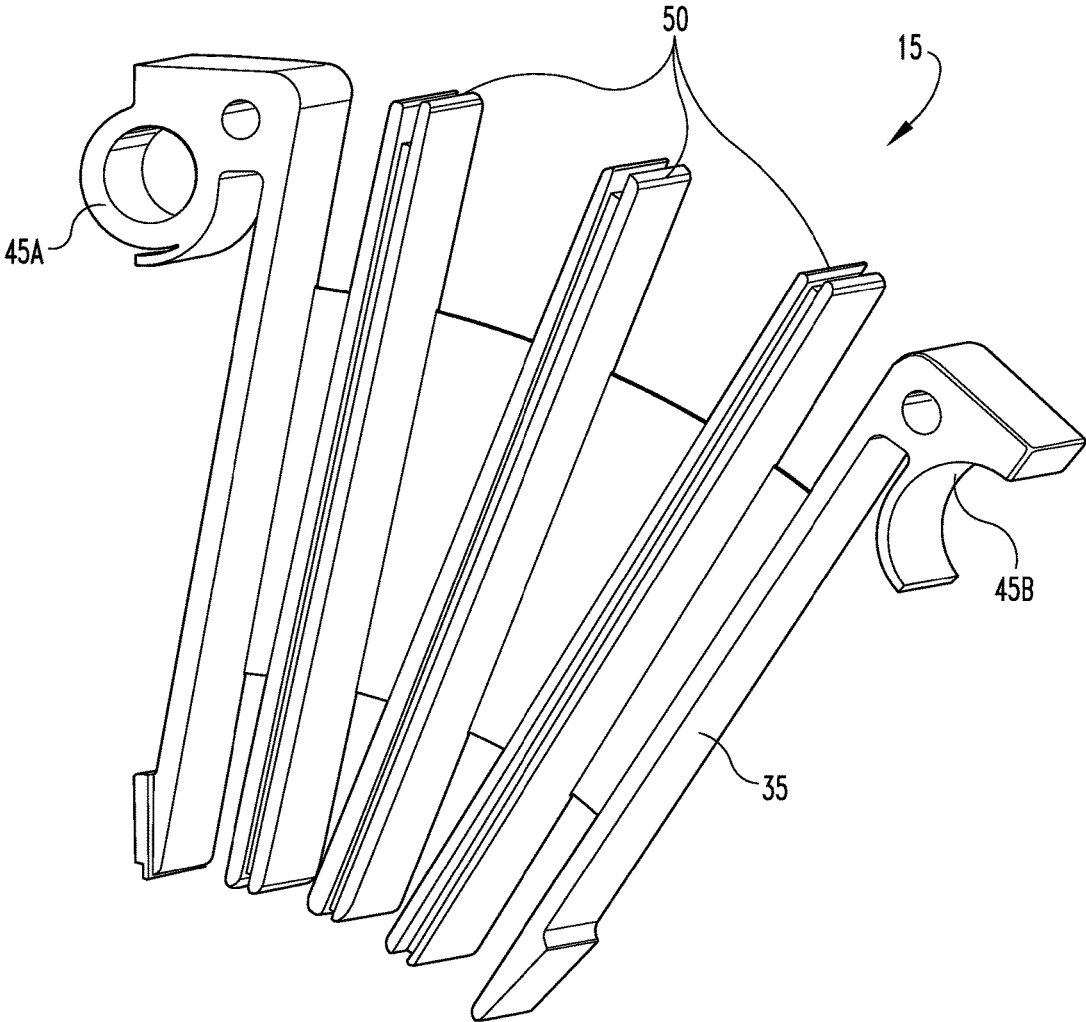

Fig. 5

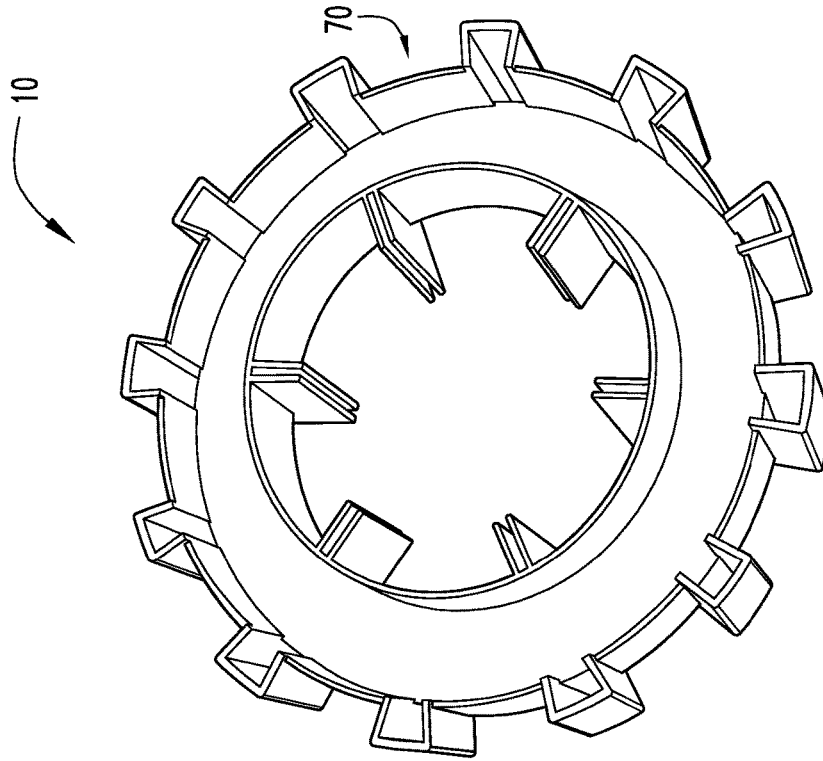

Fig. 6B

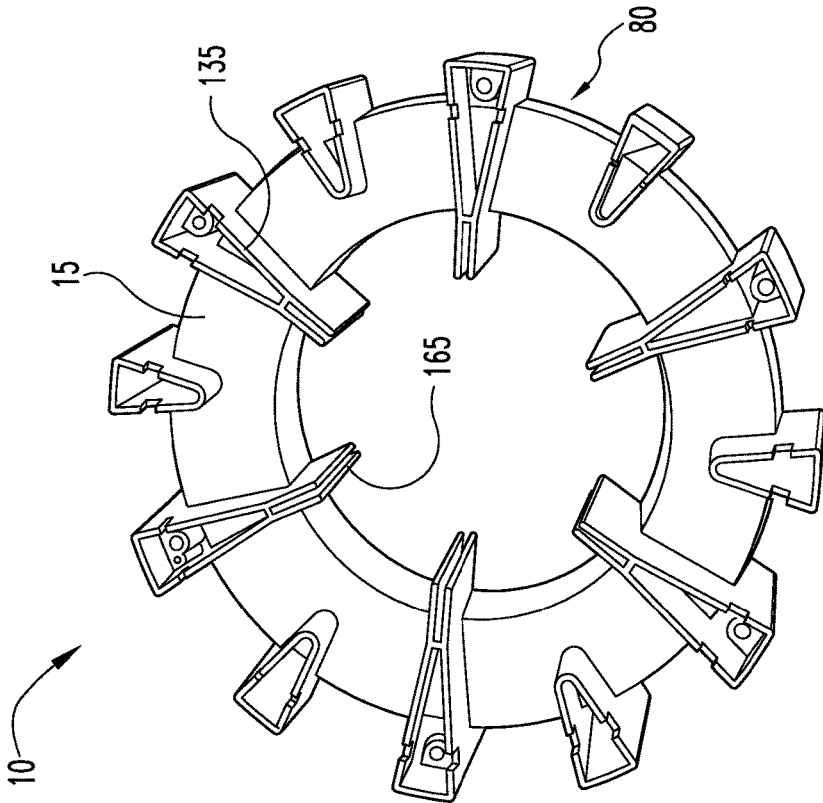

Fig. 6A

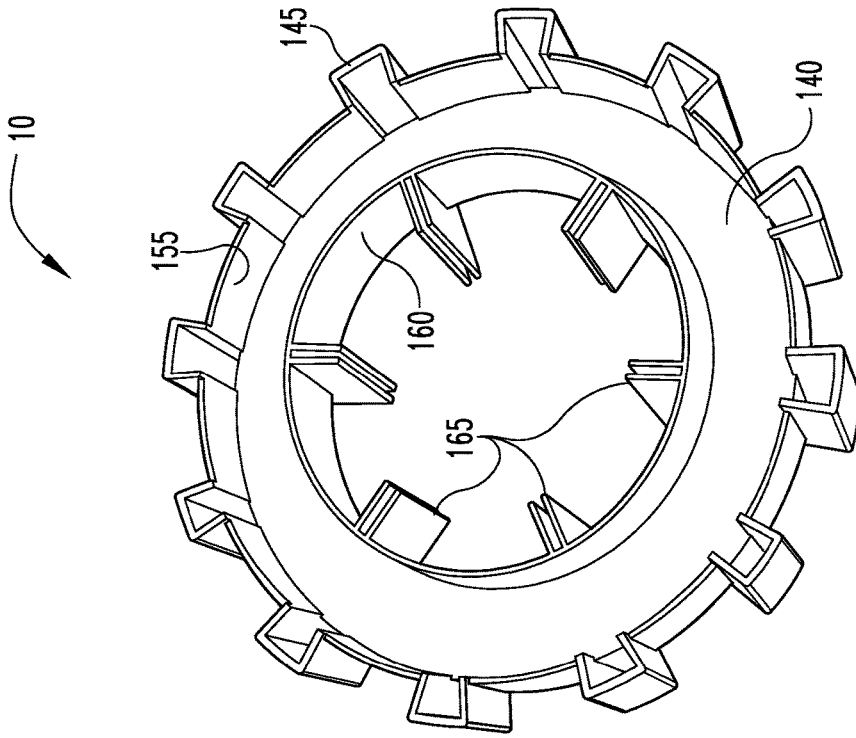

Fig. 7 B

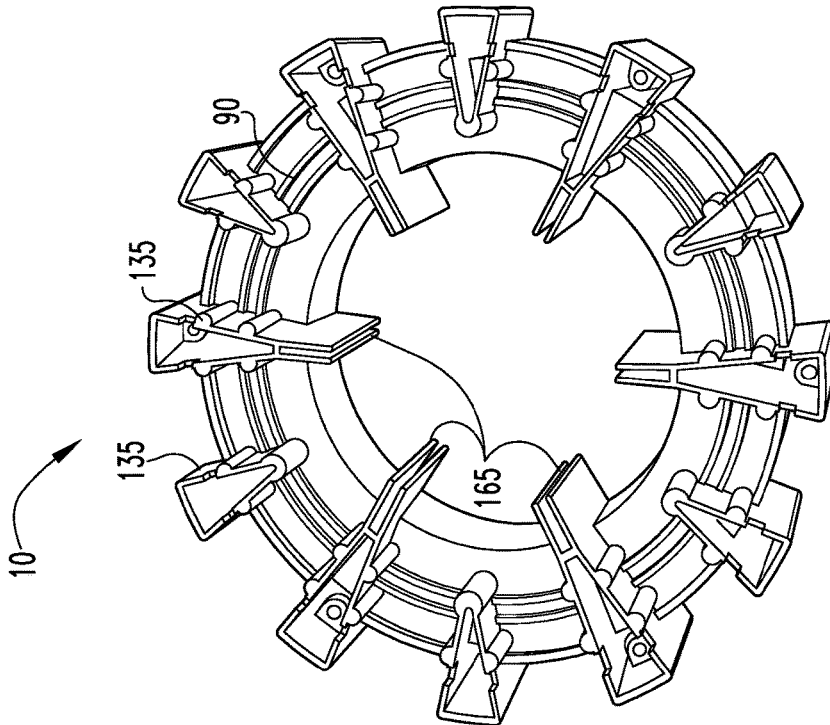

Fig. 7 A

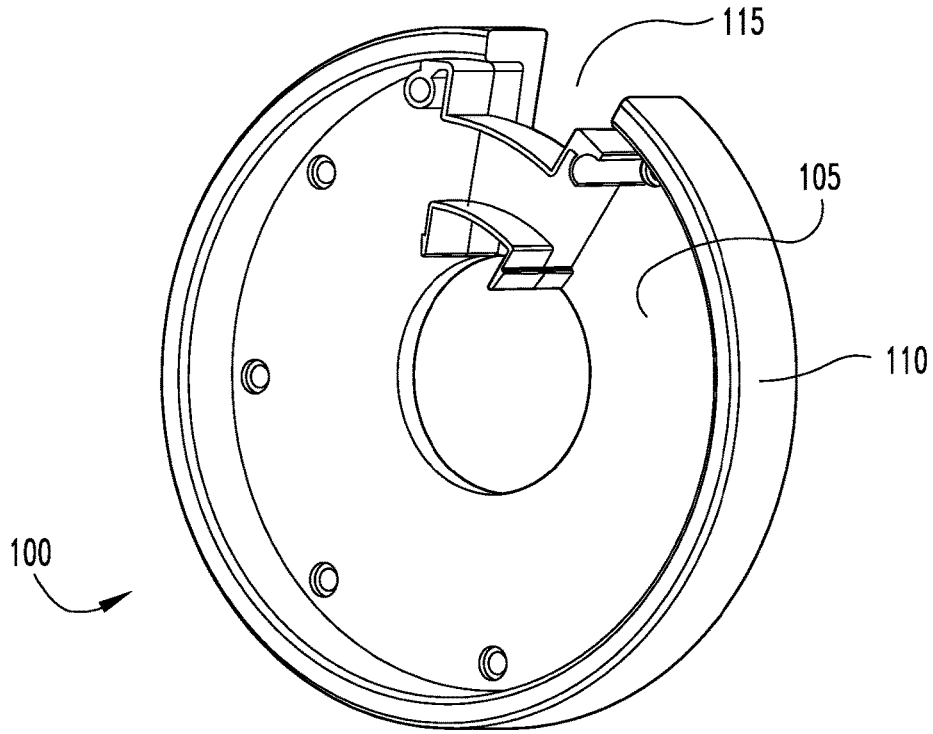

Fig. 8 A

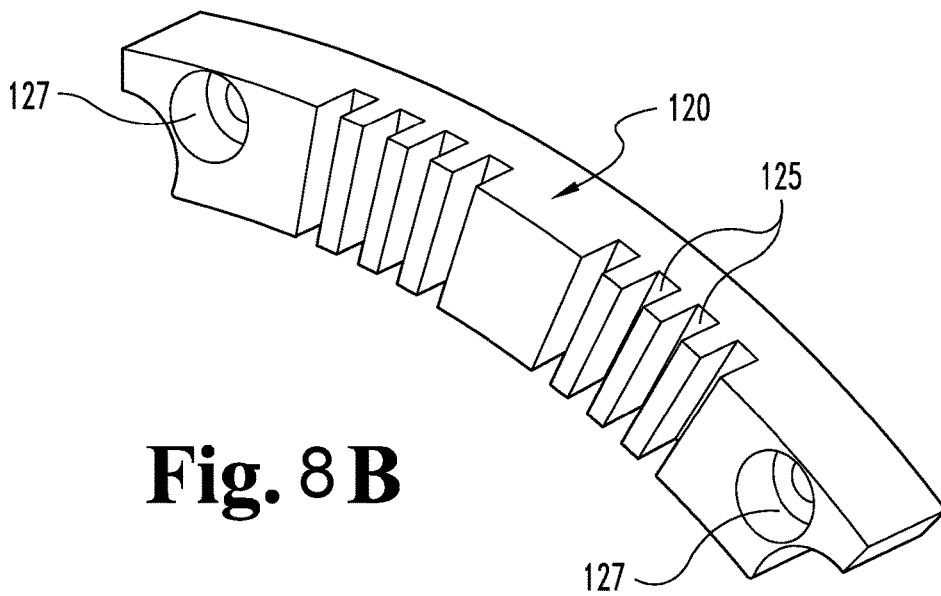

Fig. 8 B

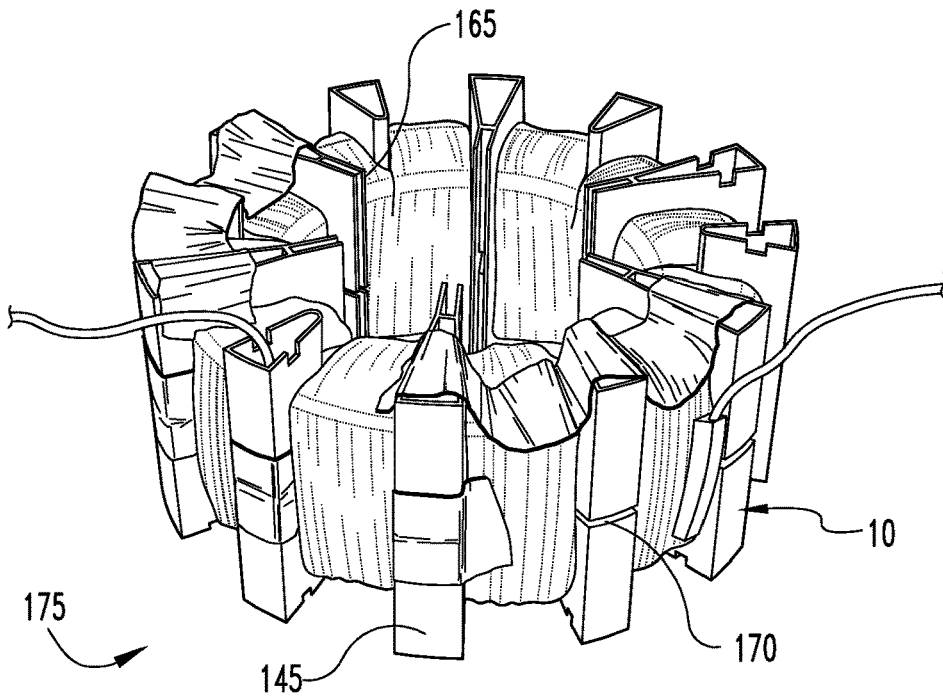

Fig. 9A

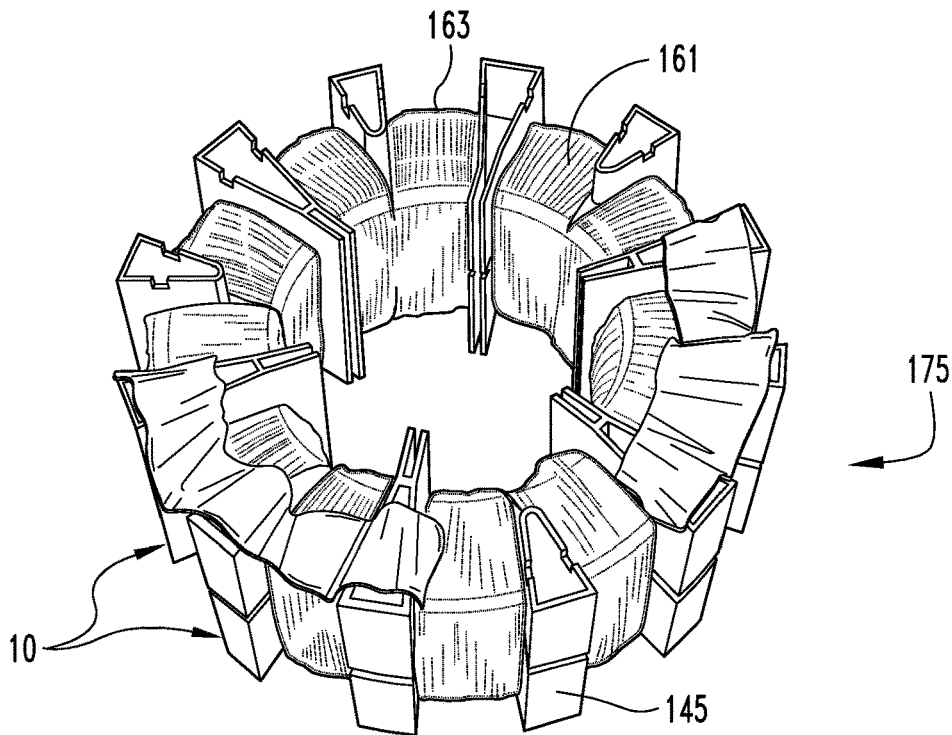

Fig. 9B

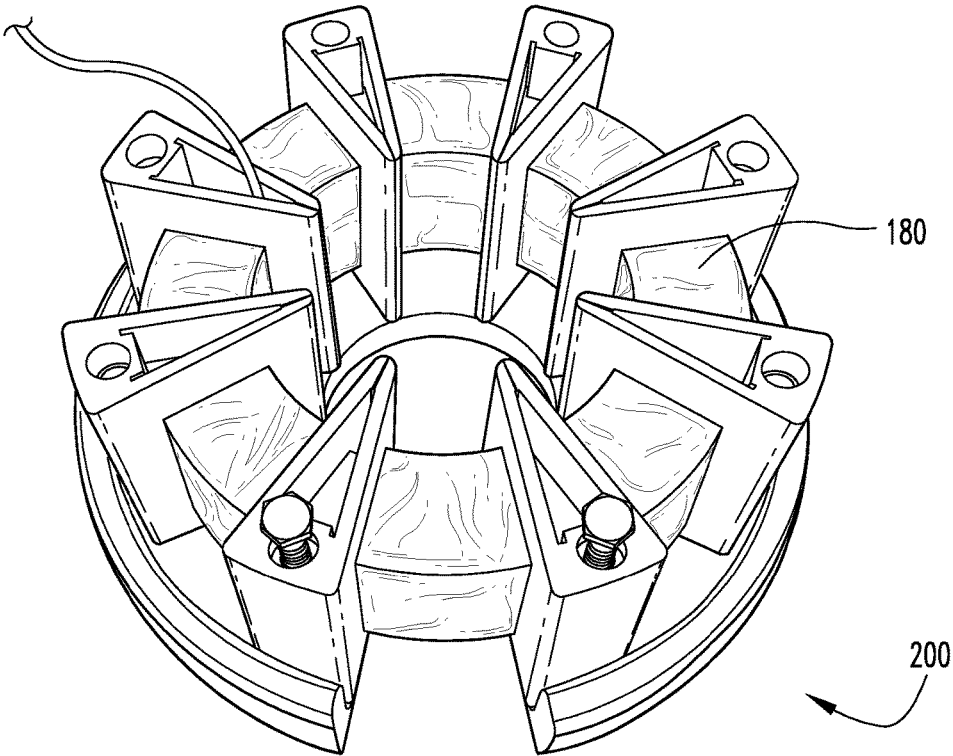

Fig. 10

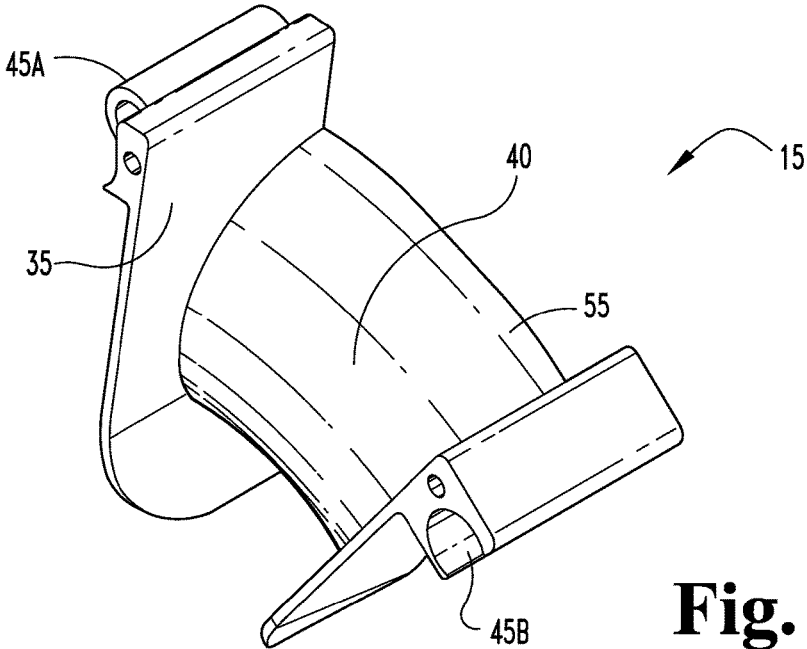

Fig. 11 A

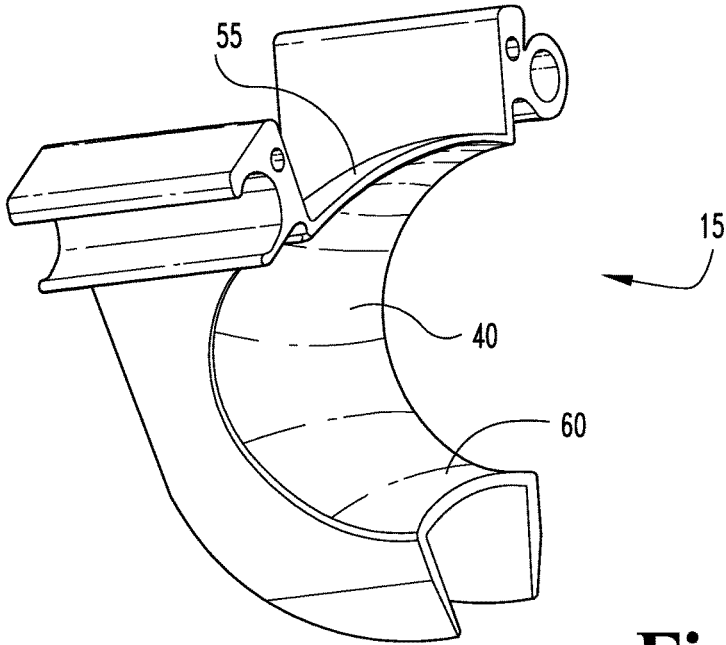

Fig. 11 B

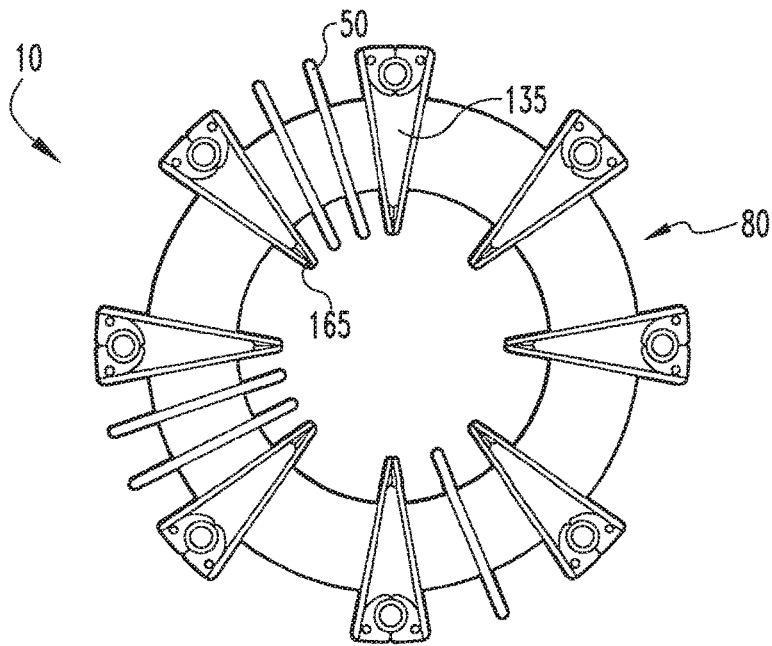

Fig. 12A

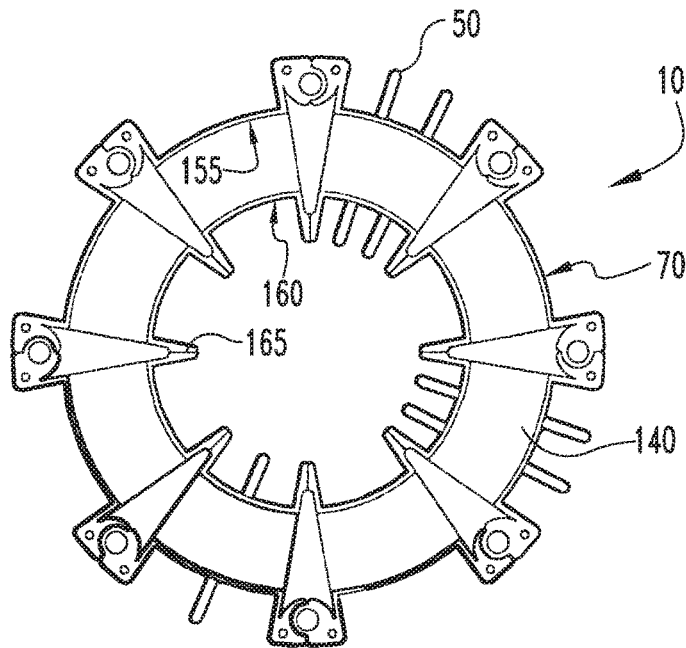

Fig. 12 B

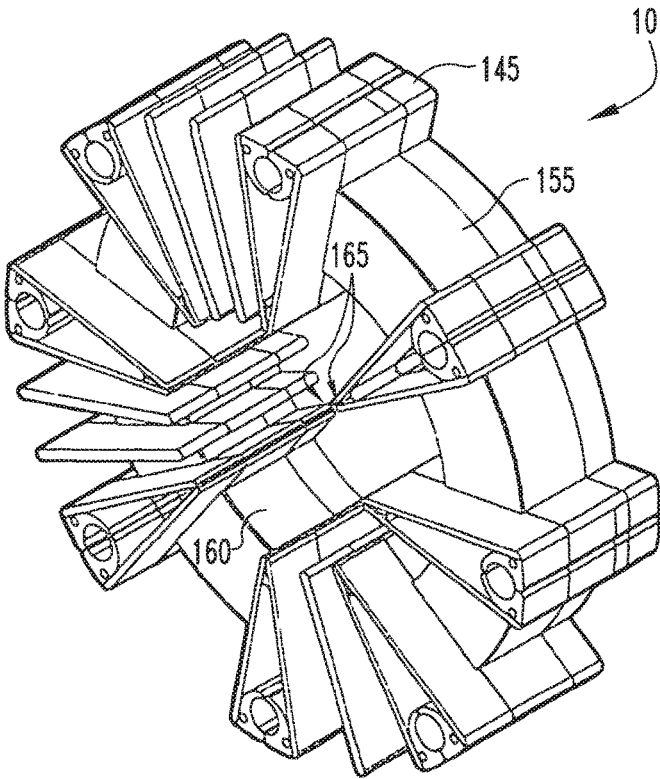

Fig. 12 C

1

SEGMENTED CORE CAP SYSTEM FOR TOROIDAL TRANSFORMERS

TECHNICAL FIELD

The present novel technology relates generally to toroidal transformer systems, and, more particularly, to a segmented core cap for use with toroidal transformer cores and a method for using the same.

BACKGROUND

A transformer is an electrical device that transfers energy between two or more circuits through the phenomenon of electromagnetic induction. Transformers are commonly used to increase (step-up) or decrease (step-down) the voltages of alternating current in electric power applications. This is accomplished by passing a varying current through the primary winding to generate a magnetic flux in the transformer's core. This flux then induces a voltage in the transformer's secondary winding. Depending on the ratio of the primary windings to the secondary windings, the transformers output voltage can be increased or decreased.

For most transformers designed for small-scale use, such as in devices commonly used in homes or offices, one of two styles of transformers is typically used. These are transformers with either an E-I laminate or a toroidal core (See FIG. 1). In a laminate transformer utilizing an E-I structure, the matching "E" and "I" components are stamped from sheets of thin grain oriented electrical steel, and the sheets are then stacked to create the core. Typically, the primary and secondary windings are wound on bobbins. Multiple bobbins are placed on spindles and spun in order to apply the windings. This method of winding the core with wire supplied on bobbins allows for automation, and so reduces the manufacturing times and also provides insulation between the windings and the core. The E-I core laminations are stacked inside the bobbins to complete the transformer.

In the case of a toroidal core, the core element is typically made from a continuous strip of silicon steel, which is wound like a tight clock spring. The ends are tacked into place with small spot welds, to prevent the coiled steel from unwinding. The core is typically insulated with an epoxy coating or a set of caps or multiple wraps of insulating film, such as MYLAR and/or NOMEX (MYLAR and NOMEX are registered trademarks, reg. no. 0559948 and 86085745, respectively, of the E. I. De Pont de Nemours and Company Corporation, a Delaware Corporation located at 1007 Market Street, Wilmington, Del. 19898). The transformer's windings are applied directly onto the insulated core itself. Additional insulation is required to isolate the windings. Since the windings must be wound through the center hole of the core and the core is one piece, bobbins can't be used on toroidal transformers.

As they do not lend themselves to automation, toroidal transformers are more labor intensive to produce. However, the continuous strip of steel used in the core allows the toroidal transformer to be smaller, lighter, more efficient, and quieter than its E-I laminate counterpart. These qualities are highly desirable in many applications and justify the additional expense.

Thus, there is a need for a toroidal transformer that enjoys the advantages of being smaller size, lighter weight, increased efficiency, and quieter operation while overcoming the draw-

2

backs of being labor intensive and more expensive to produce. The present novel technology addresses these needs.

BRIEF DESCRIPTION OF THE DRAWINGS

For a better understanding of the nature and objects of the present novel technology, reference should be made to the following drawings, in which:

FIG. 1 is a schematic diagram generally illustrating E-I and toroidal transformer designs of the PRIOR ART.

FIG. 2A is a first perspective view of a toroidal cap segment according to a first embodiment of the present novel technology.

FIG. 2B is a top plan view of FIG. 2A.

FIG. 2C is a second perspective view of FIG. 2A.

FIG. 2D is a third perspective view of FIG. 2A.

FIG. 3A is a first perspective view of a toroidal cap segment according to a second embodiment of the present novel technology.

FIG. 3B is a top plan view of FIG. 3A.

FIG. 3C is a second perspective view of FIG. 3A.

FIG. 3D is a third perspective view of FIG. 3A.

FIG. 4 is a perspective view of a toroidal cap segment according to a third embodiment of the present novel technology.

FIG. 5 is a perspective view of a toroidal cap segment according to a fourth embodiment of the present novel technology.

FIG. 6A is a top perspective view of a plurality of segments forming a toroidal core cap ring according to a fifth embodiment of the present novel technology.

FIG. 6B is a bottom perspective view of FIG. 6A.

FIG. 7A is a top perspective view of a plurality of segments forming a toroidal core cap ring according to a sixth embodiment of the present novel technology.

FIG. 7B is a bottom perspective view of FIG. 7A.

FIG. 8A is a bottom perspective view of a winding tool according to a seventh embodiment of the present novel technology.

FIG. 8B is a perspective view of a wire lock tool for use with FIG. 8A.

FIG. 9A is a perspective view of a partially wound core using the present novel technology.

FIG. 9B is another perspective view of another partially wound core.

FIG. 10 is a perspective view of a toroidal transformer including the segmented core caps of the present novel technology.

FIG. 11A is a perspective view of an eighth embodiment of the present novel technology.

FIG. 11B is a second perspective view of FIG. 11A.

FIG. 12A is a top plan view of a ninth embodiment of the present novel technology.

FIG. 12B is a bottom plan view of FIG. 12A.

FIG. 12C is a perspective view of FIG. 12A.

DETAILED DESCRIPTION

For the purposes of promoting an understanding of the principles of the novel technology, reference will now be made to the embodiments illustrated in the drawings and specific language will be used to describe the same. It will nevertheless be understood that no limitation of the scope of the novel technology is thereby intended, such alterations and further modifications in the illustrated device, and such further applications of the principles of the novel technology

as illustrated therein being contemplated as would normally occur to one skilled in the art to which the novel technology relates.

Embodiments of the present novel technology are illustrated in FIGS. 2-12B, and relate to segmented or modular electrically insulating core caps **10** for supporting primary and secondary windings, typically in alternate sectors, to reduce leakage current. Pluralities of individual modular electrically insulating segments **15** typically snap, or otherwise join, together to define annular or semi-annular modular core caps **10** for covering or partially covering a (typically steel) ring-type toroidal transformer core **20**. The segments or modules **15** are typically made from an insulating material, such as nylon, ZYTEL, or the like (ZYTEL is a registered trademark, reg. no. 71666270, of the E.I. Du Pont De Nemours and Company Corporation, 1007 Market Street, Wilmington, Del. 19898).

The core cap modules **15**/completed core caps **10** insulate windings from the core **20** over the full range of the windings, and allow for double wall insulation between adjacent windings, significantly reducing leakage current over the prior art systems. The core cap modules **15**/completed core caps **10** also provide for direct cooling of the core **20** by ambient or forced air without intervening insulation. The core **20** may be assembled from component modules **15** over a completed, wound toroidal core **20**. The core caps **10** allow for winding **25** of the transformer **30** using standard winding equipment while maintaining a direct path for waste heat to escape, as there is no need for interwinding insulation that can trap heat. Further, the core caps **10** eliminate the need for center fill epoxy and/or mounting washers, so the weight of the transformer **30** is reduced.

In most embodiments, the segments **15** each include a pair of spaced, typically electrically insulating, wall members **35** between which a core covering panel portion **40** is connected. The wall members **35** intersect to define a typically wedge-shaped and/or pie-piece shaped segment **15**, or a truncated wedge or pie-piece shaped segment **15** when the walls **35** would intersect at or near the center of the cap **10** if so extended, and are disposed at a predetermined angle relative to each other, typically 30 degrees, 45 degrees, 60 degrees, or the like so that each modular segment **15** spans an arc of about 30 degrees, 45 degrees, 60 degrees or the like. The respective spaced walls **35** include removably engagable, typically male and a female, connector portions **45A**, **45B**, respectively, such that adjacently disposed segments **15** may be repeatedly removably engaged with one another, with sufficient connected segment portions **15** defining an annular core cap **10**. The number of segments **15** required to complete a core cap **10** is predetermined and is typically a function of the predetermined angle between the walls **35**; for example, if the angle is 45 degrees, eight segments **15** will be required to be connected together to define a ring **10**. If the angle is sixty degrees, only six segments **15** will be required to define a ring **10**. While core caps **10** are typically built from identical core cap modules **15** core caps **10** may alternately include combinations of core cap modules **15** spanning different arcs, such as four core cap modules **15** spanning forty-five degrees each and six core cap modules **15** spanning thirty degrees each. While identically sized and shaped modules **15** are typically more convenient, there are no practical restrictions on the combinations of core cap module **15** sizes and shapes that may be combined to yield a custom core cap **10** having desired properties and characteristics.

Typically, the walls **35** engage the panel **40** to define a relatively flat or flush core-engaging side or surface (defining the bottom or underside **70** of the segment **35** and ring **10**, located in the downward direction) and disposed opposite the barriers **75** established by two joined or locked together walls **35** (defining by the wire-segmenting or top-side **80** of the ring **10**, located in the upward direction). The barriers **75** define the parameters between which alternating wire windings are restricted, typically alternating primary and secondary windings.

In some embodiments, the segments **15** include one or more separation or wall members **50** positioned to partially or completely extend across the top-side **75** of the panel **40** to further define parameters between which wire windings are directed. The one or more separation members **50** are typically positioned equidistantly between the walls **35** and/or each other **50**, respectively. The one or more separation members **50** are typically oriented to extend radially outwardly from the center of the core **20** and/or the annulus **10** defined by the joined segments **15**; in other words, each respective separation member **50** typically lies on a radius of the annulus **10**, although the separation walls **50** may have other convenient shapes and contours as desired.

In some embodiments, the segments **35** further include a core outer diameter or OD cover panel **55** and/or a core inner diameter or ID cover panel **60**, both extending downwardly so as to at least partially cover the OD and ID, respectively, of a toroidal core ring placed against the core cover panels **40** of a partially or completely formed annulus **10**. These panels **55**, **60** may be flat for covering a core ring **20** having flat outer and inner diameter sides, or curved to follow a core ring **20** having a rounded or curved inner and outer diameter portions (see FIGS. 11A-11B)

In some embodiments, the wall members **35** are truncated and do not extend across the panels **40**. In some of these embodiments, lower wall members **65** are positioned opposite the panel **40** from the respective wall members **35**. The lower wall members **65** may likewise include matable connectors for co-joining.

In some embodiments, the segments **35** include ribs positioned on the upper side of the panels **40**, so as to generate an air gap between wire windings and the top-side **80** of the ring **10**. The production of an air gap facilitates air cooling of windings by allowing air to circulate between windings and the top-side **80** of the cap **10**.

In some embodiments, a winding tool **100** is included to facilitate the winding of a capped core from a single bobbin. The winding tool **100** is typically a flat ring **105** having a projecting rim or flange no extending from the outer diameter thereof. The ring **100** typically includes a slot **115** formed there through, such that the ring no has a C-shape. The ring no is sized to accept a segment **15** therein, with the slot **115** sized to pass wire onto a segment **15** aligned therewith. Winding tool **100** further typically includes an elongated arced wire lock member **120** having a plurality of slots **125** formed partially therethrough and one or more locking apertures **127** formed therethrough for connecting the wire lock member **120** to one or more segments **15** during the wire winding process.

In operation, a plurality of segments **15** may be connected to one another to define a ring **10**. The ring **10** includes an annular core top cover portion **140** defined by the panels **40** of the individual segments **15**. In most embodiments, the ring **10** also includes (typically) equidistantly spaced radial protrusions **145**, defined by mutually engaged connectors **45A**, **B**, extending outwardly from the ring **10**. Each radial protrusion **145** is typically part of an elongated wall member

135 positioned on the topside **80** of the ring **10** and extending radially inwardly partway or completely across the topside surface **80**. Some of the walls **135** terminate in radial protrusions **165** extending inwardly from the ring **10**. These radial protrusions **165** are typically formed from the joiner of two lower walls **65**, although they may be formed separately.

The ring **10** may also include an annular core outer diameter cover member **155** and/or an annular core inner diameter cover member **160**, each cover member **155**, **160** positioned generally perpendicular to the core top cover portion **140** and extending downwardly away therefrom. The respective cover members **155**, **160** are typically composed of adjacent cover panels **55**, **60** when the segments **15** are connected to define the ring **10**.

Typically, a pair of cap rings **10** are constructed from connected segments **15** and positioned on opposite sides of a toroidal core **20** with outward protrusions **145** aligned. Typically, an even number of segments **15** are connected to make each ring **10**. Wire is wound contiguously around alternating segments **15** to define the primary windings **161**, with **N** windings per segment **15**. Wire is wound contiguously around the remaining segments **15**, in multiples of **N** windings per segment **15**, to define the secondary windings **163**. Typically, all of the windings **161**, **163** may be accomplished from a single bobbin or shuttle in one contiguous bobbin winding **25** operation, with wire guided from one segment **15** to the next through the groove or gap **170** between the two opposite core caps **10**. The wire is typically cut or severed to isolate the primary windings **161** from the secondary windings **163**, and the wound core **175** may then be wrapped in insulation **180** to define a toroidal transformer **200**. In some embodiments, the winding tool **100** may be utilized to facilitate core winding. Coils **20** so wound retain the advantages of toroidal transformers while enjoying the benefits of being lighter, smaller, more efficient and quieter than E-I laminate cores. Cores **20** so wound exhibit reduced interwinding leakage current when compared with standard wound toroidal transformer cores.

Typically, the primary windings **161** will occupy the odd numbered segments **15**, starting with the first segment wound, and the secondary windings **163** will occupy the even numbered segments **15**. In some embodiments, each ring **10** may contain multiples of three segments **15**, such as six, nine, or twelve, and the core **20** may be wound with primary **161**, secondary **163** and tertiary (not shown) windings as above to yield a three-phase transformer. In other embodiments, the ring may contain segments **15** having different configurations (see FIGS. **12A-12C**).

In some embodiments, an insulating material, such as a MYLAR strip, is positioned to cover the portion of the core **20** exposed by the gap **170**. In other embodiments, the core **20** is partially or completely wrapped in an insulating material prior to the positioning of the cap(s) **10** thereupon. In still other embodiments, wall members **35** are spaced and oriented relative each other to define an annulus, but are not physically connected to each other. In most embodiments, the wire wrapping the core **20** is sheathed in an insulating layer or film.

While the novel technology has been illustrated and described in detail in the drawings and foregoing description, the same is to be considered as illustrative and not restrictive in character. It is understood that the embodiments have been shown and described in the foregoing specification in satisfaction of the best mode and enablement requirements. It is understood that one of ordinary skill in the art could readily make a high-infinite number of insub-

stantial changes and modifications to the above-described embodiments and that it would be impractical to attempt to describe all such embodiment variations in the present specification. Accordingly, it is understood that all changes and modifications that come within the spirit of the novel technology are desired to be protected.

We claim:

1. A modular toroidal transformer core cap system, comprising:
 - a plurality of cap segments, wherein each respective cap segment further comprises:
 - first and second spaced elongated wall members;
 - a first connector member connected to the first elongated wall member;
 - a second connector member operationally connectable to a respective first connector member of another respective cap segment and connected to the second elongated wall member;
 - a generally flat panel member connected to and extending between the first and second elongated wall members;
 - wherein the first and second wall members are disposed at a predetermined angle relative one another;
 - wherein the angle between the first and second spaced elongated walls defines an arc;
 - wherein the first and second wall members cooperate to define a wedge; and
 - wherein the first and second elongated wall members and the panel member are electrically nonconducting; and
 - wherein an integral number of cap segments may be removably engageably joined together to define an annular core cap.
2. The modular toroidal transformer core cap system of claim **1** wherein the angle between the first and second elongated wall members is 30 degrees.
3. The modular toroidal transformer core cap system of claim **1** wherein the angle between the first and second elongated wall members is 60 degrees.
4. The modular toroidal transformer core cap system of claim **1** wherein the angle between the first and second elongated wall members is 45 degrees.
5. The modular toroidal transformer core cap system of claim **1** and further comprising a first elongated curved cover member extending between the first and second elongated wall members and a second spaced elongated curved cover member extending between the first and second elongated wall members, wherein the respective cover members are oriented generally perpendicular to the panel member and wherein the panel member is disposed between the respective spaced cover members.
6. The modular toroidal transformer core cap system of claim **1** wherein the segments are made of nylon.
7. An annulus for covering a toroidal transformer core to facilitate winding, comprising:
 - a plurality of connected annulus segments, each respective segment further comprising:
 - at least two spaced elongated support members defining an arc;
 - a first fastener connected to the first elongated support member;
 - a second fastener connected to the second elongated support member, wherein the first and second fasteners are removably engageable with respective second and first fasteners of other respective annulus segments;

7

a generally flat core cover member extending between the first and second elongated support members; wherein the first and second support members are disposed at a predetermined angle relative one another; and wherein the first and second elongated support members and the flat core cover member are electrically nonconducting; and wherein a predetermined number of annulus segments may be joined together to define the toroidal core covering annulus.

8. The annulus of claim 7 wherein the respective generally flat core cover members collectively define a core covering ring.

9. The annulus of claim 7 wherein each segment further comprises a core outer diameter cover member extending between the first and second elongated support members and a spaced core inner diameter cover member extending between the first and second elongated support members, wherein the respective diameter cover members are oriented generally perpendicular to the respective flat core cover members and wherein the respective flat core cover members are disposed between the respective spaced diameter cover members.

10. The annulus of claim 7 wherein the angle between the first and second elongated support members is selected from the group comprising 30degrees, 45 degrees, and 60 degrees.

8

11. A ring cap system for covering a toroidal transformer core, comprising:

a plurality of ring segments, each respective ring segment further comprising;

at least two spaced elongated support members;

a first fastener extending from the first elongated support member;

a second fastener matingly connectible to a respective first fastener of another respective ring segment and extending from the second elongated support member, wherein the first and second connectors are repeatedly removably engageable; and

a flat core cover member extending between the first and second elongated support members;

wherein the first and second support members are disposed at a predetermined angle relative one another; and

wherein the first and second elongated support members and the flat core cover member are electrically nonconducting; and

wherein a predetermined number of annulus segments may be joined together to define a toroidal core covering ring.

12. The system of claim 11 wherein the predetermined number is six.

13. The system of claim 11 wherein the predetermined number is eight.

* * * * *